

MOUNTING INSTRUCTION FOR WINDOWS

MODEL

VI70SP

Content

General conditions	3
The instruction covers.....	3
Content of delivery	3
Type of wall/fastening	4
Mounting.....	5
Tools for mounting.....	5
Before mounting	5
Control of wall opening.....	5
Distances between wall and frame.....	6
Mounting of U-flashing/angle flashing	7
Mounting of frame.....	8
Mounting of glass and glass list	9
Filling in adhesive	11
Principle drawings of steel windows.....	12
Cleaning after mounting	13
Documentation	13

General conditions

- It is essential for the technical properties of the window that it is installed correctly in accordance with these installation instructions.
- The window must be installed by qualified personnel.
- The person/company installation the window is responsible for ensuring that the window is installed correctly.
- If the content or nature of the insulation is changed, the frame is milled, cut, drilled or other work is carried out, the technical properties of the window may deteriorate.
- In the event of loss of or damage to the window sign or nameplates, the nameplates must be re-established.
- If you need to change the window, contact Door System A/S is recommended.

The instruction covers

This mounting instruction covers all variations of the models mentioned on the front page. A variation is indicated by the model number and subsequently different letters and possibly numbers. A variation could be (based on model VI70SP): VI70SPT. Marked fire-approved windows are NOT covered by this installation guide.

Content of delivery

Description	Comment
Frame - window profile	
Glass or thermal glass	
Glass list	
Window sealing	
Styrolit adhesive profile	
Sloping bottom profile over glass list	
Extension frame	Option
Wall flashing	Option
Necessary bolts, washers, screws and blocks for installation	

Type of wall/fastening

The following wall types are approved for the VI70SP window:

- Min. 80 mm wall with a density of min. 850 kg/m³ (e.g. block wall, masonry, concrete).
- Min. 100 mm wall with a density of min. 650±200 kg/m³ (e.g. aerated concrete, concrete, masonry). The window must be moved at least 20 mm from the wall edge if it is to be installed in a heavy wall.
- Min. 70 mm flexible wall (e.g. plaster) built with a skeleton wall of either wood or steel. Around the wall opening, a screw-resistant base must be made in the form of a wooden stud or steel profile. A stainless-steel skeleton should be 2.0 mm, while a galvanized steel skeleton should be 2.5 mm. The thickness of the wooden frame must be at least 45 mm.
- Min. 70 mm panel wall. Around the window hole, a screw-proof base MUST be made in the form of steel U-flashing. The thickness of stainless steel for the U-flashing in one part must be min. 2.0 mm, The thickness of stainless steel for the U-flashing in two parts must be min. 1.5 mm.

Approved fixing elements:

Rigid wall: M7.5 x 92 mm frame screws with head.

Flexible wall: M8 x 80mm Insex-screw cylindrical and washers.

It is possible to use alternative fasteners for walls with a density of min. 850 kg/m³ and heavy walls with a density of min. 650±200 kg/m³ with steel concrete screws min. \varnothing 7.5 mm. Bolt length in the wall must be min. 50 mm. Alternative fasteners for plaster and panel walls are steel screws min. \varnothing 6.3 mm and bolt length min. 50 mm.

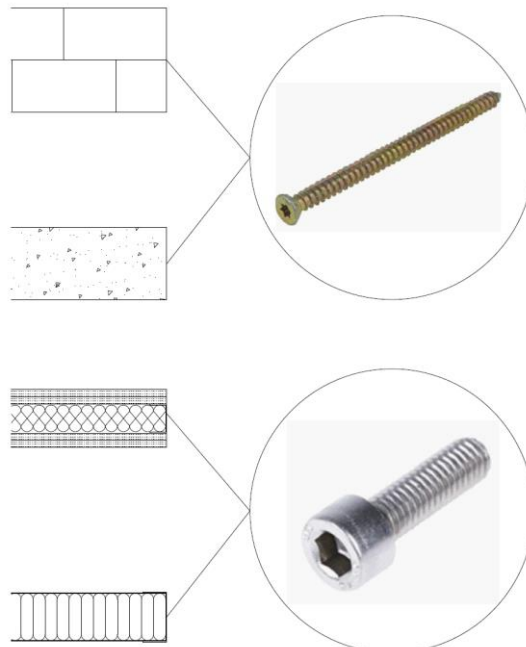

Mounting

Tools for mounting

Wedges/chocks
Spirit level
Power drill/screwdriver
Styrolit adhesive profile
Adhesive

Before mounting

Control of wall opening

Make sure the wall opening is level and perpendicular and in accordance with the order confirmation.

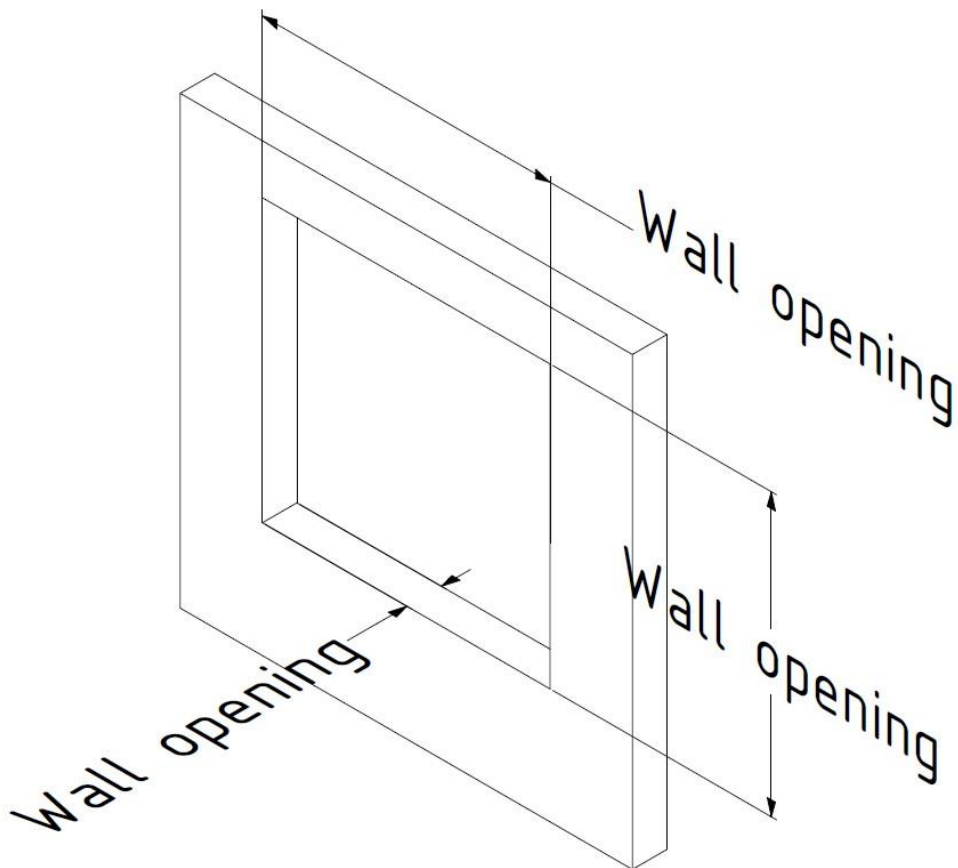

Distances between wall and frame

The sealing width is the distance between the window frame and the wall. The distance must not be less than 10 mm or more than 30 mm in any place – see the figure below.

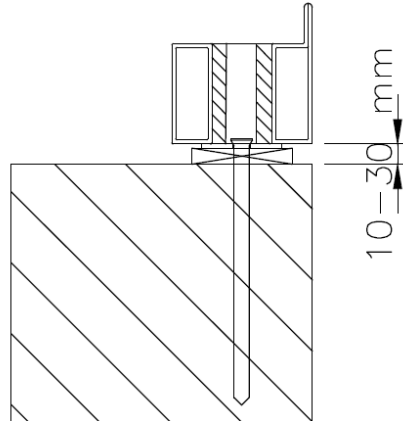

If the requirements are not kept, the wall opening has to be adjusted, so the requirements can be fulfilled. This adjustment is to be agreed with the owner of the door. The company/person who mounts the window is responsible for this agreement.

Mounting of U-flashing/angle flashing

First, wall flashing is installed, if it is stated in the order confirmation. Flashing is used for quick and easy installation, protection of the wall edge and aesthetic expression around the window. In addition to aesthetics, the flashing also protects the wall edge from wind and weather if the window is to be installed in the façade. The flashing is mounted with blind rivets $\varnothing 3.2$ mm, screws or glue to the wall and sealed with adhesive.

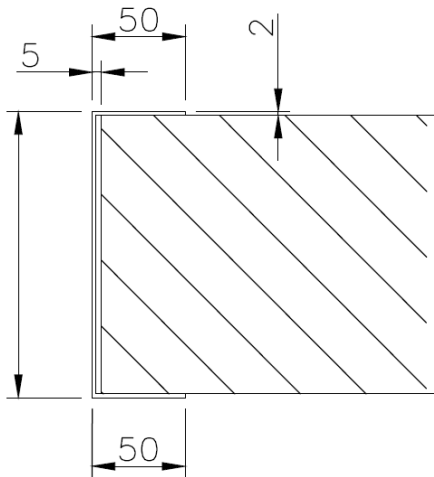

U – flashing

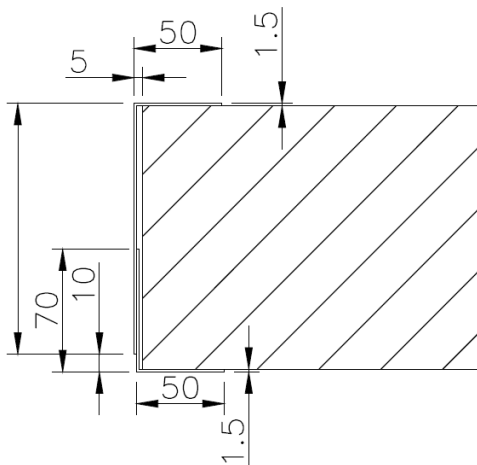

U - flashing in 2 parts
(if wall thickness is varied)

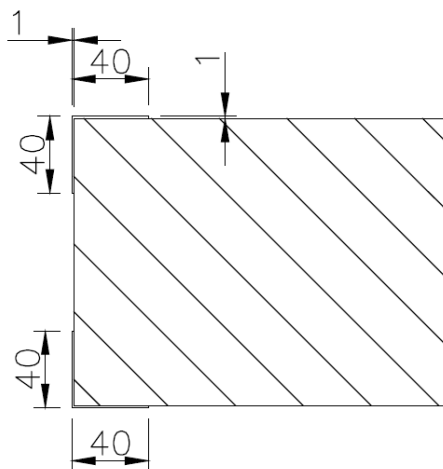

Angle flashing 40x40

Mounting of frame

Before final fastening of the frame, the following must be checked:

- The frame is level both horizontal and vertical.
- The distance between the frame and the wall according to the figures in the section “Distances between wall and frame”.

The frame is installed with or without an additive frame. The frame is bricked with K-blocks (plastic) of different thicknesses.

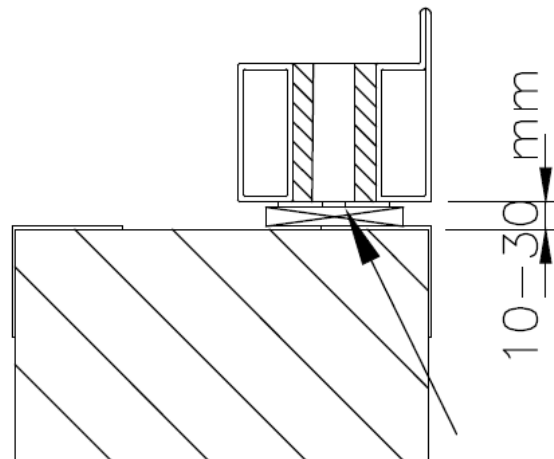

The frame is prepared with mounting holes $\varnothing 15$ mm and underlying mounting brackets $\varnothing 8.5$ mm, where the frame is to be attached. Drill holes ($\varnothing 10$ mm for concrete, lightweight concrete, block wall or masonry or $\varnothing 6.5$ mm for steel skeleton wall) in the masonry through the mounting holes and secure with the supplied fasteners.

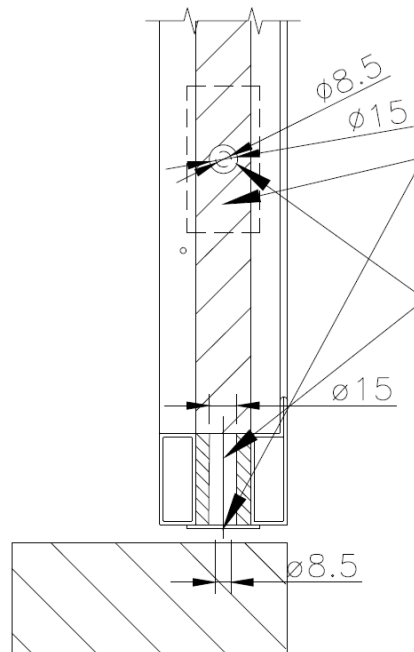

Mounting of glass and glass list

When the frame and possibly the flashing are fixed in the wall hole and all dimensions have been checked, glass and glass strips are mounted on the frame.

The frame is supplied with holes $\varnothing 3.3$ mm for the glass strip screws. The supplied glass strip screws are mounted along a straight line. Control dimensions are 13 mm from the edge of the frame.

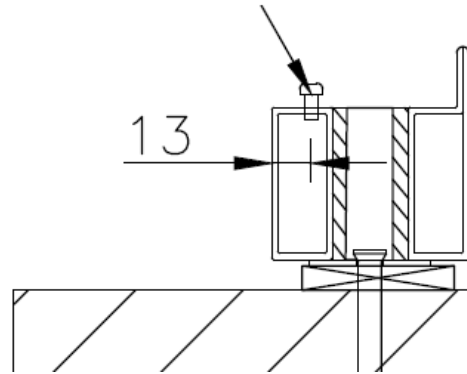

Put window sealing on profiles and glass strips. The window must have 2 layers of 4 mm window sealing on the glass strip and 1 layer of 4 mm window sealing on the frame.

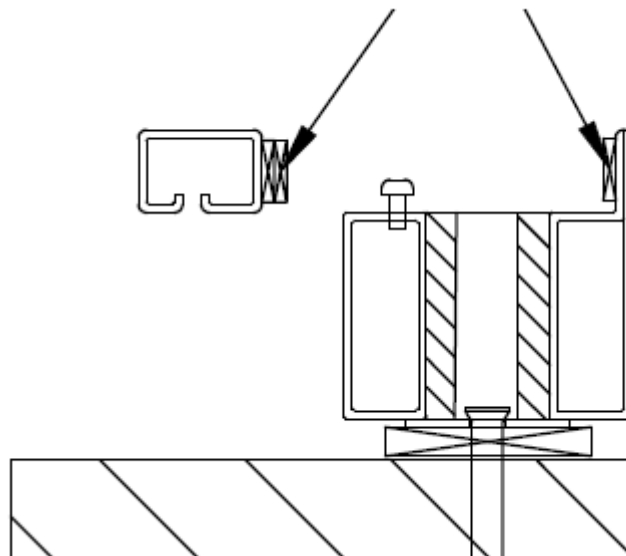

If there is a problem with space, use window sealing with a thickness of 1, 2, 3 or 4 mm.

Install glass blocks between the frame and the glass. Measure the distance between the frame and the glass. The glass must be centered so that the distance is equal on both sides. Different sizes of glass blocks are used depending on the type of window:

- a) for SP you need 23x6 mm glass block.
- b) for SPT you need 25x6 mm glass block.

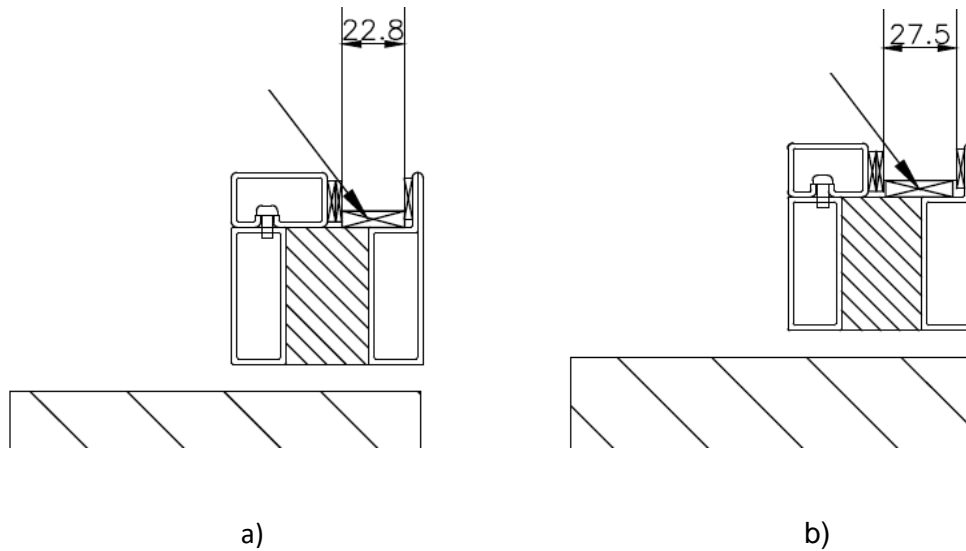

After mounting the glass block and glass, the glass strip must be applied to hold the glass in place in the frame. The glass strip is assembled with 90° joint in corners and at any bars. Horizontal glass strip should be full-length.

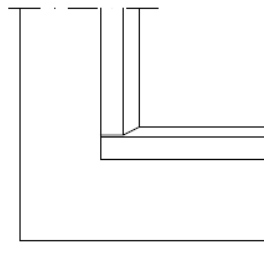

Use a plastic or rubber mallet to secure the glass strips over the glass skirting screws. The glass strip must be kept straight when attaching to the glass strip screws, otherwise there is a risk of damaging the glass.

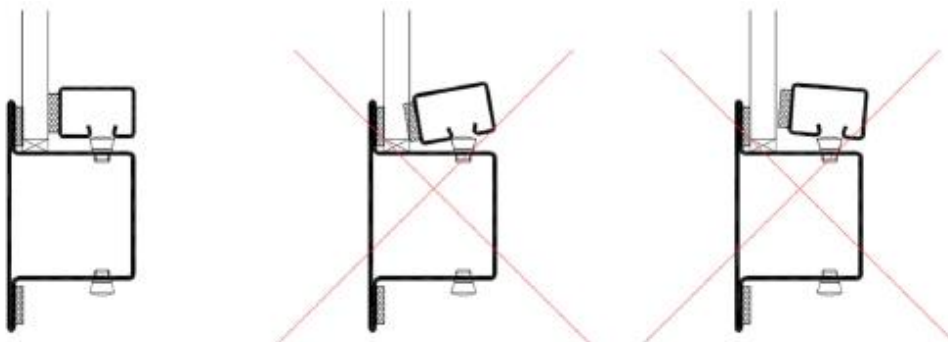

Hit one end of the glass strip. Hit the edge of the glass strip and directly over the glass strip screw. If the glass strip is hard to hit, try using a wooden or plastic block to help.

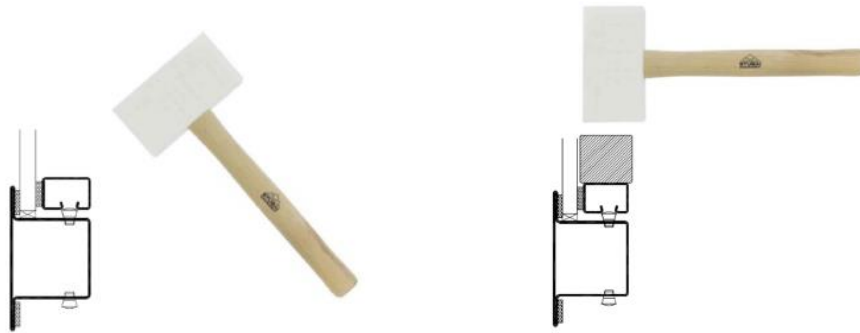

A sloping base profile can be mounted over the horizontal glass strip. The sloping bottom profile is pressed down between the glass and the glass strip. The window seal must be mounted on the sloping bottom profile towards the glass before it is pressed down between the glass and the glass strip.

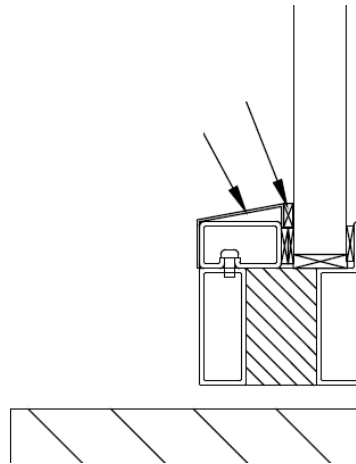

Filling in adhesive

Frame:

- The joints between the frame and the adjacent building parts must be well stopped with Styrolite joint profile (joint bottom/backstop soft).
- All joints are sealed with sanitary silicone sealant.

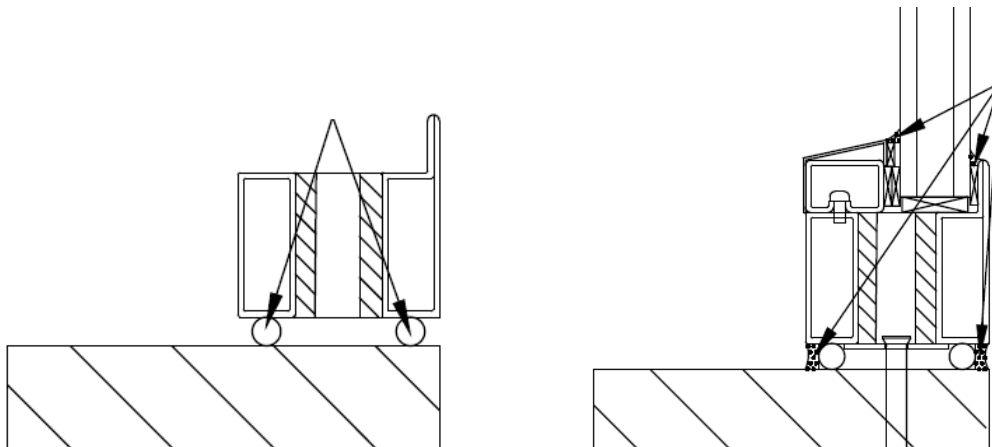

Principle drawings of steel windows

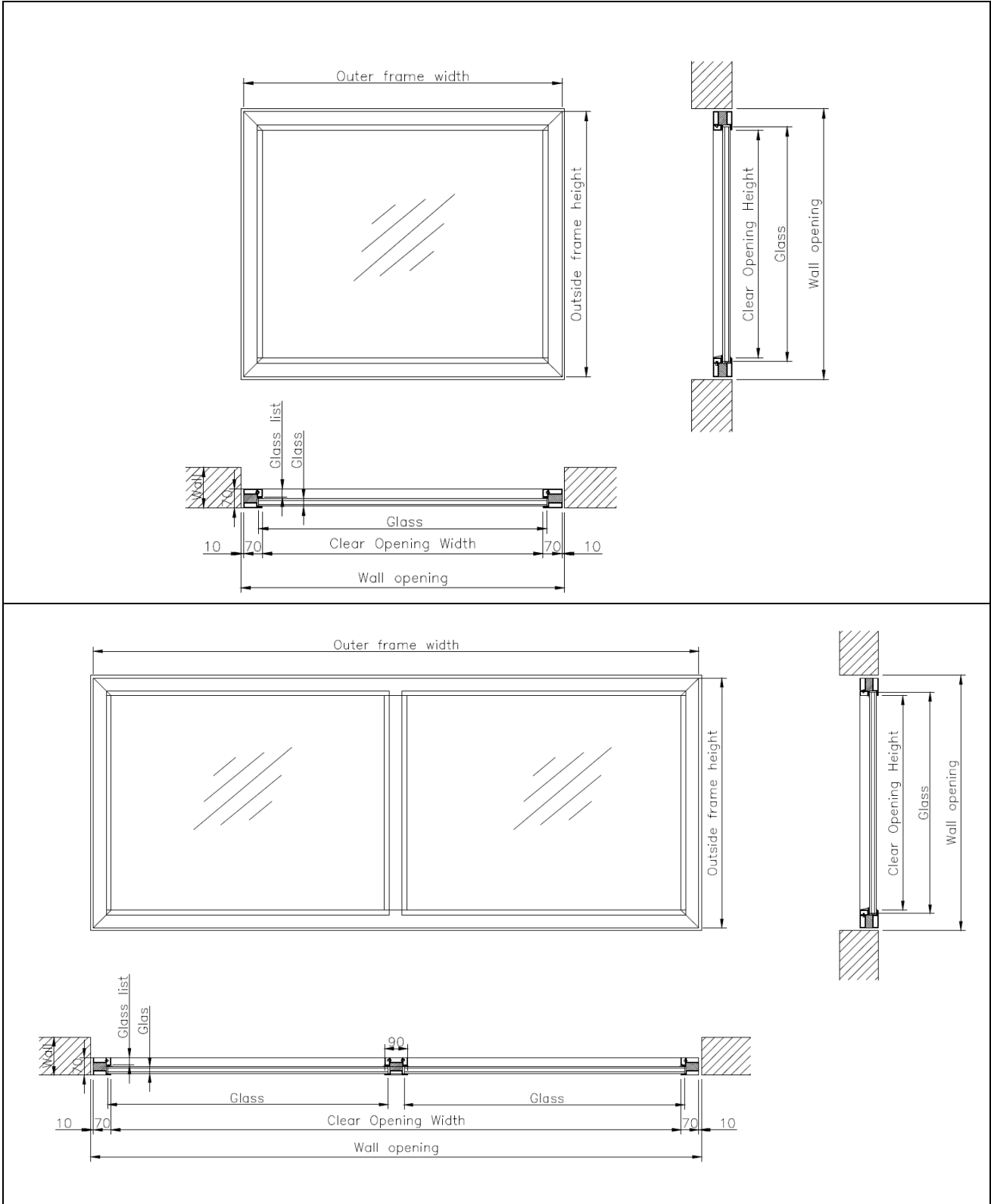

Cleaning after mounting

- Make sure that the window is fixed and that the glass has not been damaged.
- Make sure that the frame has been cleaned of dirt.
- Any foil on the frame is removed.
- Stainless steel frames are oiled with oil intended for stainless steel windows and intended for the environment in which the window is installed.

Documentation

Make sure the label is attached to the window.

The following documents have been prepared for the window:

- Operation and maintenance manual