

# Operations and maintenance manual

Automatic and manual  
sliding doors

## Content

---

General safety precautions .....	2
General information .....	2
Warnings .....	2
Sliding door use .....	3
Limited use .....	4
Storage and unpacking .....	4
Mounting the sliding door .....	4
Power-up of automatic door .....	4
Disposal .....	4
General information about sliding doors .....	5
Technical specifications .....	6
Sliding door projection .....	7
Definition of sliding directions .....	7
Definition of wall opening measurement and clear opening .....	8
Functional descriptions (options) .....	9
Push panel .....	9
Pull chord .....	9
Radar .....	10
Radio control .....	10
Induction loop .....	10
Fire Safe System (ABDL) .....	10
Heating wire .....	10
Other options .....	10
Operations and maintenance .....	11
Statutory inspection .....	13
Repairing faults .....	14
Spare part list .....	14

## General safety precautions

---

### General information

---

This operations and maintenance manual applies to both manual and automatic sliding doors and must be read carefully before putting the door into operation. Be particularly attentive to safety information.

The description of the current door appears on the page before the table of contents. Automatically operated sliding doors; door users should receive thorough door operation instructions.

It is important to adhere to the service intervals to achieve the longest possible service life. Sliding doors should be serviced by authorised services engineers.

This manual is primarily intended for operators, maintenance and cleaning personnel. The complete user manual for the door consists of an assembly guide (supplied only when Door System is not responsible for the assembly of the door, but can be found on the website), operation and maintenance manual and documentation for CE marking (if the door is CE marked).

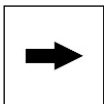



**Sliding doors have a compulsory annual service inspection.**

### Warnings

---

This manual contains warnings in the text at certain points, where the reader should be particularly attentive to personal safety or in relation to the operations of the equipment. Warnings are displayed in the following levels:

 Caution	<b>Caution</b> Potentially harmful situation. Possible consequences: slight or minor damages. Products or items close by could be damaged.
 Warning	<b>Warning</b> Potentially dangerous situation. Possible consequences: bodily harm or serious equipment damage.
 Note	<b>Note</b> Important information about a product or parts of the user manual, requiring special attention.

## Sliding door use

The sliding door can be used in all industries for separation of 2 spaces e.g. at temperature differences, fire requirements or separation of functions. Sliding doors are often used if there is a need of a large clear opening or if it is most appropriate in terms of space or function. The door is either manually operated or operated by the use of push buttons or signal from various remote controls. The door can open horizontal or vertically. Modifications or changes on the door which affects the safety of the door is not allowed.

In principle, there are no limits as to how often the door is opened and closed, however, the time intervals between service and maintenance may vary depending on the door usage. Door system recommend a preventive service and maintenance depending of the door width after the following number of cycles:

### Automatic sliding doors - recommended service and maintenance

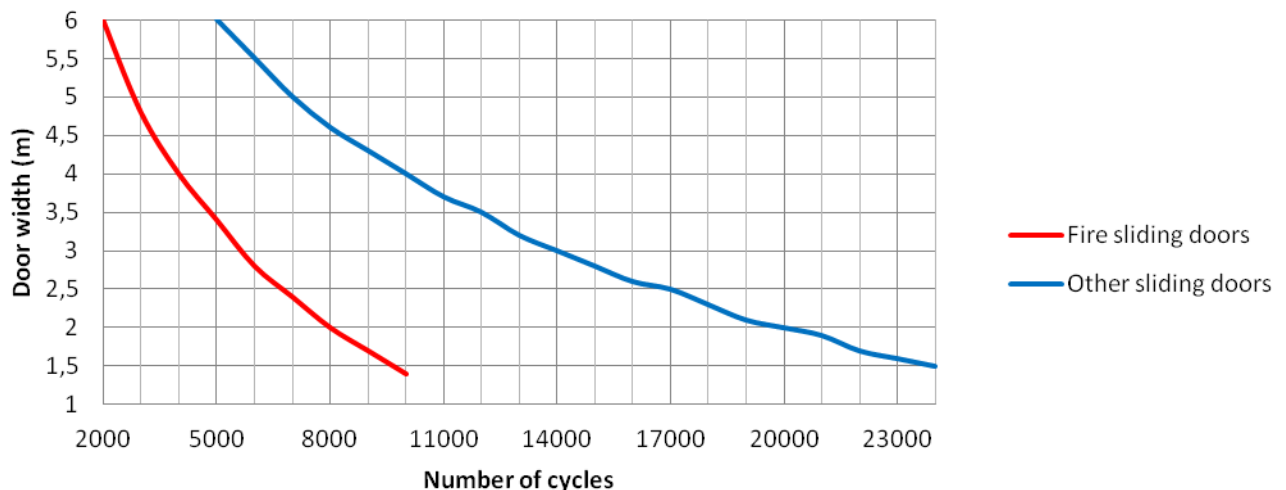

If the recommended service and maintenance are not performed, Door System disclaims all guarantees for damages caused by the lack of service and maintenance.

Fire doors/fire adapted doors are in principle always open and only in case of fire they automatically closes.



If fire doors/fire adapted doors or very heavy doors are used as regular sliding doors and thus, experience many cycles, you must expect to change wear parts often.

## Limited use

---



Staying in the door opening is discouraged, as you risk the door closing if the photocells are not activated<sup>1</sup>, or if the port receives a signal for this.



By power failure or release of the fire control system (ABDL) the safety functions of the doors is disconnected and the door closes (unless the door has a back-up system<sup>1</sup>).



Do not stay at the back rim of the door when it is moving, as you risk squeezing injuries between the door leaf and wall, when the door opens. Can be warded off by mounting a truck guard or security at the back.



Fire doors must be able to close unhindered in the event of a fire.



Be aware that automatic gates can be set in terms of closing speed for particularly vulnerable user groups, refer to the Door Control document



Be aware of regulations concerning escape routes and the use of sliding doors.

<sup>1</sup>applicable to automatic doors

## Storage and unpacking

---

Usually, the doors are delivered in a crate wrapped in plastic.

If the door is not mounted upon receipt, it should be stored indoor and protected against moisture and variation in temperature.

The door is checked immediately upon receipt.

Check if the packaging is intact before unpacking the door. If the packaging is damaged, thoroughly examine the content for damages.

In case of damages, inform both the haulage contractor and Door System. The damages must be documented in a report and including pictures to be sent immediately to Door System.

## Mounting the sliding door

---

In cases, where the sliding door is not mounted by Door System's own service engineers, instructions for mounting are included in the package. Instruction for mounting is also available at [www.doorsystem.dk](http://www.doorsystem.dk)



It is the customer's responsibility that the wall opening measurements matches the order confirmation, unless it is measured by Door System's own staff.

## Power-up of automatic door

---

We refer to a separate manual "Door control", found in the control box.

## Disposal

---

The door must be disposed off according to the national current environmental legislation and regulations in force at the time in question.

## General information about sliding doors

---

By default, the doors are supplied in a side sliding configuration, but can also be made as vertically sliding doors.

The doors are supplied either as manually or automatically operated doors.

If you choose automatic operation, the sliding doors are either driven by means of a belt drive or toothed bar drive. A toothed bar drive is used for cold store or freezer rooms as well as for very heavy doors.

The door leaf is mounted with wheels within the sliding rails at the top of the door leaf. The frame is mounted around the wall opening. The A-rail is where the door leaf rests when the door is closed. The B-rail is where the door leaf rests when the door is open. Depending on the door's width, the B-rail may be supported by a rail support. The motor is either placed at the end of the A-rail or at the end of the B-rail.

Sliding doors can be combined with other automatic systems e.g. belt conveyors, lock systems or washing machines. Likewise, the sliding doors can be fitted with various operation options for the automatic open/close function.

Fire sliding doors has a counter weight, which make the door close when the fire control system is activated (. The counter weight can be placed at the front leg (at the end of the A-rail) or at the rear leg (at the end of the B-rail).

The door opens either manually or by activating push-button, pull chord, induction loop or via remote control. See descriptions of these functions in the section "Functional descriptions (options)".

In automatic doors, there is a horizontal photocell mounted in the bottom edge of the door leaf and a vertical photocell in the top of the door leaf. These photocells ensure that the door does not close, when the photocells are activated, thereby avoiding squeezing.

The same safety is not available when the door opens and there is a risk of squeezing between the wall and door, when the door opens. Door System recommends that the door movement area is screened off, possibly by truck guard or by fitting extra sensors.

The description of the current port can be seen on the page before the table of contents.

## Technical specifications

The table below shows possible options for the construction of a sliding door (for a description of the current door, refer to the description on the page before the table of contents).

Door types:	Manual operation Automatic operation Fire door Chill door Freezer door
Door thickness:	40, 60, 80, 100, 150 mm
Design:	Door leaf made with strait top and side or a 78° chamfer on the top and side.
Insulation types:	Polyisocyanurate (PIR) foam Firebatts for fire doors
Plate material:	Galvanised steel Painted steel Stainless steel AISI304 Stainless and acid-proof steel AISI316
Frame material:	Strong stainless steel profile
Sliding rail material:	Extruded anodised aluminium
Safety devices <sup>1</sup> :	Photocells on door leaf Photocell in frame leg Motor surveillance
Opening speed <sup>1</sup> :	Variable from 0,3-0,6 m/sec Set to 0,4 m/sec. from the factory
Closing speed <sup>1</sup> :	Variable from 0,3-0,5 m/sec.
Control unit <sup>1</sup> :	CPU-based. Fault indicator and frequency converter as standard fittings
Voltage:	230V
Power:	16 Amp
Motor <sup>1</sup> :	0,55 kW, 1,1 kW or 1,5 kW
Frequency converter <sup>1</sup> :	1,1 kW, 1,5 kW
Pulse generator <sup>1</sup> :	Push panel with emergency stop as standard fitting
Operating temperature:	-20°C to +40°C
Options:	Pull chord switch <sup>1</sup> Radar <sup>1</sup> Radio control <sup>1</sup> Induction loop <sup>1</sup> Fire Safe System (ABDL) Window Lock Personnel door/emergency hatch

<sup>1</sup> applicable to automatic doors

Sliding door projection

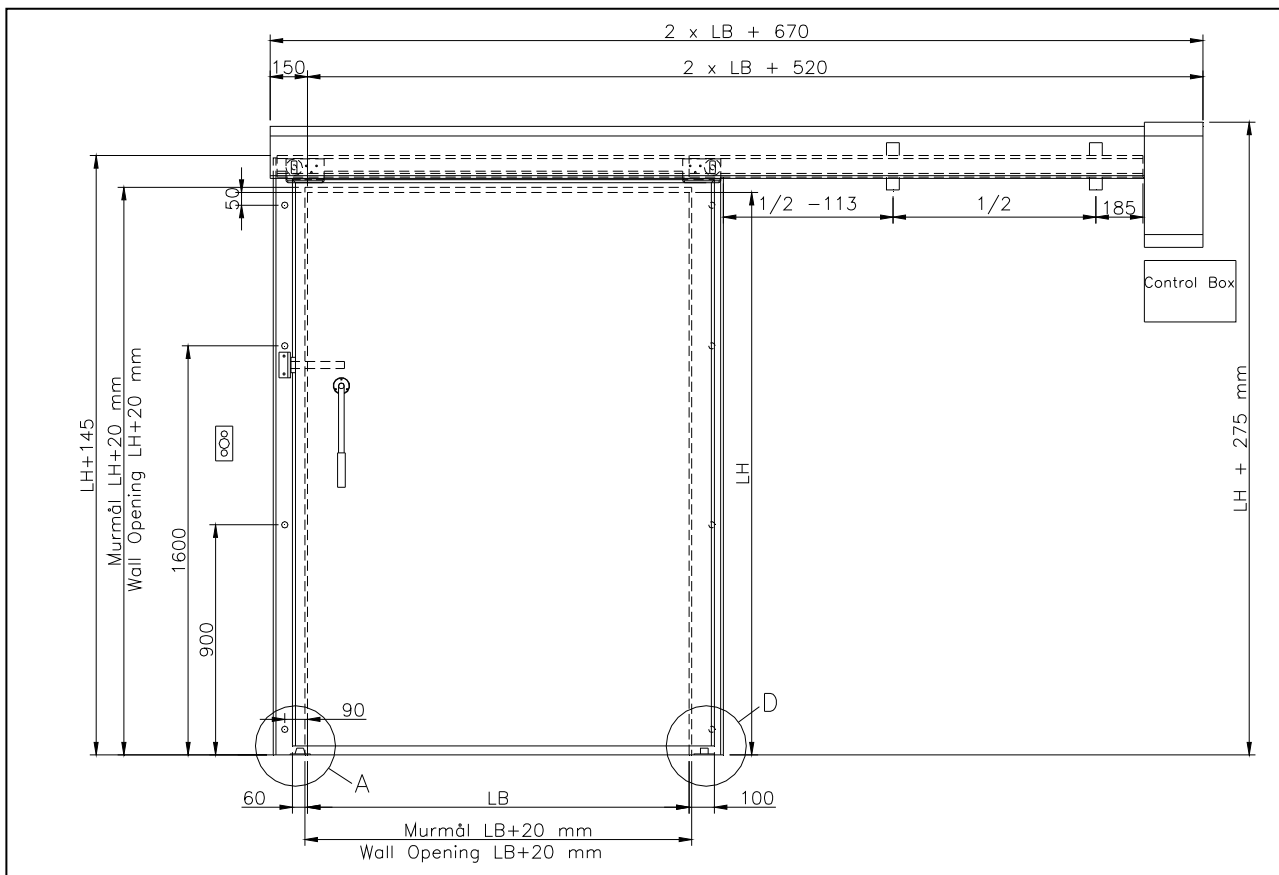

Definition of sliding directions

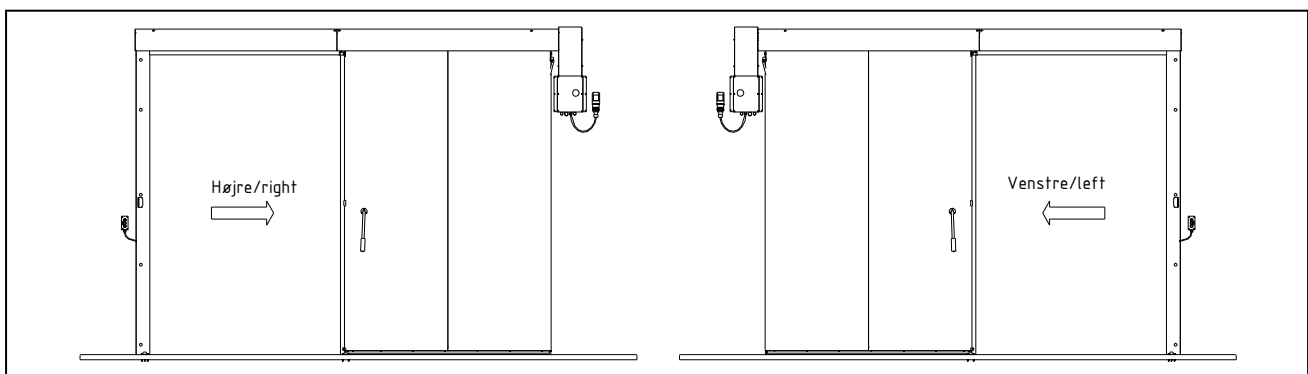



Definition of wall opening measurement and clear opening

**Wall opening measurement:**

Vertical distance between the 2 walls as well as the horizontal distance between the top of the hole and floor, and the thickness of the wall, is called the WALL OPENING MEASUREMENTS.

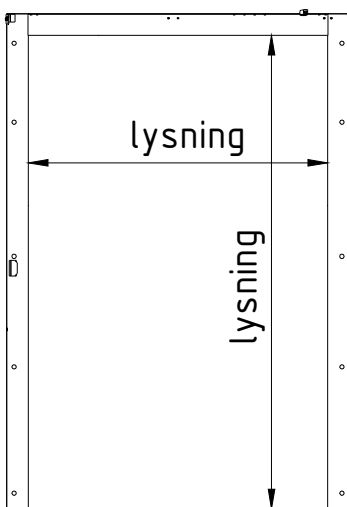
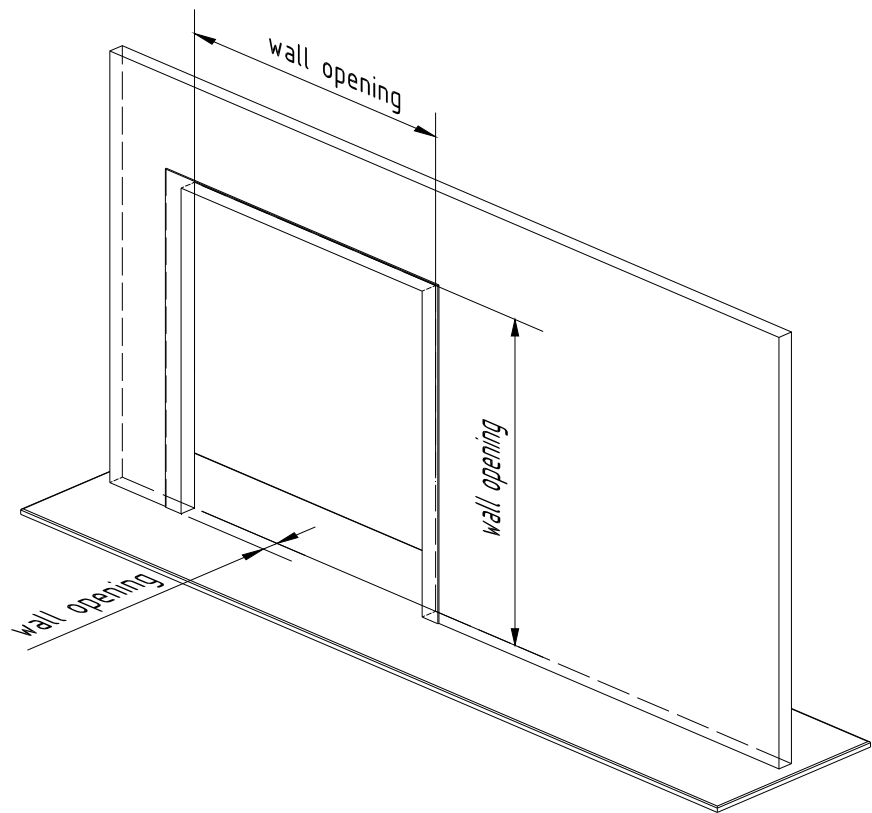

**Clear opening:**



Vertical distance between the 2 frames at the side of the door and the horizontal distance between the bottom of the upper horizontal frame and the floor/threshold, is called the Clear opening. In other words, the light visible

through the hole. If the door is without a counterframe, the clear opening will be the same as the wall opening.

## Functional descriptions (options)

### Push panel

The push panel is always delivered with an automatic sliding door. The panel is a box with push-buttons mounted on the wall next to the door. There is a push-button to open, one to close and an emergency stop. At a single push of the close-button the door closes from completely open to completely closed and can only be changed by activating the photocells, open-button or the emergency stop. At a single push of the open-button the door opens from completely closed to completely open. The door cannot be stopped by activating the photocells but can be changed by pushing the close-button or emergency stop.

	<p><b>Located on the backside of the door opening</b></p> <p>White push-button = open (regardless of opening direction)</p> <p>Emergency stop</p> <p>Black push-button = close (regardless of closing direction)</p>		<p><b>Located on the front of the door opening</b></p> <p>White push-button = open (regardless of opening direction)</p> <p>Emergency stop</p> <p>Yellow light push-button = close (regardless of closing direction)</p> <p>When the button lights up, this indicates a stoppage outside normal operations.</p>
--	--	---	---

In some cases, when an ABDL system is connected, an extra green push-button is available on the control panel or on a separate press panel. This push button works as a test button for functional testing of the door.

*If the emergency stop has been activated, the button must be turned clockwise to release the stop.*

### Pull chord

The door is opened by pulling a chord and the door automatically closes after a certain period of time. The time is set on the timer. This means that even though the door is already open, the pull chord must still be activated or the door might begin closing, while you are moving through it. The pull chord can also be set at a tilt function, meaning that the pull chord must be activated when opening the door and again when closing the door. Pull chord can only be used on automatic doors.

## Radar

---

The radar can be used either as safety or to activate the door.

If the radar is used as safety radar, it will always open, if the door is active, when there is movement in front of the door. If the radar is used to activate the door, the door will open when there is movement within the radar's "visual field". The door will close after a given period. The time is set on the timer.

It is possible to install safety radar on one side of the door and open/close radar on the other side of the door. This is to provide extra certainty of avoiding damages to persons or materials.

Radar can only be used on automatic doors.

## Radio control

---

Radio control is a remote control of the door, often utilised in locations with truck traffic.

Radio control can only be used on automatic doors.

## Induction loop

---

Magnetic field, which is buried in the floor. It registers when metal enters the area and opens the door. The door closes after a given period of time. The time is set on the timer.

Induction loop can only be used on automatic doors.

## Fire Safe System (ABDL)

---

ABDL is used in connection with fire doors. ABDL is an abbreviation of Automatic Fire Door Closing (Automatisk Brand Dørs Lukning) and ensures that the fire door automatically closes in case of fire using a counterweight. ABDL is connected to the door control (automatic door) or magnet (manual door). OBS! If ABDL is activated, the port's security functions are disabled.

The ABDL facility must be inspected and maintained every two years by an authorized electrical installation company.

## Heating wire

---

Heating wire can be used for doors fitted with a large temperature difference, to break the cold migration and reduce the risk of condensation. At the door to the freezer compartment, the heating wire must not be connected if the freezer is switched off, as overheating may occur and the heating wire may be damaged.

## Other options

---

Sliding doors are available with:

- Window
- Lock
- Personnel door or emergency hatch.

## Operations and maintenance

Ongoing preventive maintenance is essential for the operation of the door. If some parts does not function as intended, the safety and functionality of the door can be disturbed.

The best way to secure the optimal conditions for the door, to make sure the safety on the door is ok and to optimize the lifetime of the component in the door are by continuously maintenance of the door. The maintenance of the door should be performed regularly and minimum as described below. The life expectancy of the door is up to 50 years when regular maintenance is performed.

It is the responsibility of the owner of the building to maintain the door as described below. Annual service inspection is statutory on automatic doors. Inspection of fire doors and of the fire control system (ABDL) is also statutory at least ones a year. Door System recommend service inspection of the fire doors is performed at least ones a year by a qualified service technician.

When maintaining and servicing the door, measures must be taken so that no risks arise, e.g. by using signage or disconnecting automation (where possible).



*For the daily operations to be as smooth as possible, it is important that the maintenance items below are checked/carried out regularly.*

	Subject	Control item	Control:					
			Visually	Annually	Bi-annually	Quarterly	Monthly	Daily
1	Sealing strips	When closed, any sealing strips must close tightly between the door leaf and frame/floor. If sealing strips are damaged, and do not sit flush with the frame or bottom guide rail, they should be replaced.	X				X	
2	Sliding rails	The sliding rail must be kept free of foreign objects that could hinder the movement of the rollers. The sliding rail should be lubricated with grease (e.g. Food Grease Plus) on the fall-out 1-2 a year or when required (i.e. the rollers begin to make a noise).	X		X			
3	Rollers	The rollers should be changed either when deformed, the diameter is at Ø56 or the roller shaft begins to touch the guide rail. Rollers should be lubricated with grease when required.	X				X	
4	Bottom rail	The bottom rail must be checked 1-2 a year or as needed, the rollers should be replaced, when the diameter reaches approx. 24 mm.	X		X			
5	Frame	In case of ice on the frame, remove ice.	X					X

	Subject	Control item	Control:						
			Visually	Annually	Bi-annually	Quarterly	Monthly	Daily	
6	Heating wires	Check at the heating wires work by feeling the frame. The frame must be free of ice. If the freezer compartment is switched off, the heating wire must not be connected.	X						X
7	Photocells/radar	Photocells/radars must be checked. This is done by holding something in front of the photocell/radar in order to return the door to its open position.	X						X
8	Emergency stop	Emergency stop must be checked. This is done by activating the emergency stop and checking that the gate stops.	X						X
9	Levers and locks on the sliding doors	Greased when required (e.g. using Food Grease Plus) If the handle and lock begin to be tight, difficult or noisy during use, they must be lubricated. However, fire sliding doors EI260 must not be lubricated.			X				
10	Personnel door/emergency hatch	If the sliding door is equipped with a personnel door or an emergency hatch, hinges, levers and lock boxes must be tested for functionality and greased. The personnel door/emergency hatch is opened and closed (/locked), if this cannot be done easily, the unit must be lubricated.						X	
11	Wire at wire barrel (fire doors)	Check that the pull wire is held tight by the wire barrel and that the wire is not damaged. If the wire is deformed or broken, it must be replaced. The wire must run in the wire wheel.	X					X	
12	Wire barrel (fire doors)	Check that the wire barrel can move freely up and down in the rail (achieved by lightly pulling the wire)	X					X	
13	Electromagnetic grip (fire doors)	The magnet mounted on the guide rail is tightened if necessary. In case of rust on the magnet and magnet holder, these must be changed. The magnet and magnet holder can advantageously be lightly lubricated with oil to prevent rust formation.	X					X	
14	Control of selfclosing function (fire doors)	The self-closing function of the door is checked by releasing the magnet. The door must be able to close completely on the counterweight.	X				X		
15	ABDL-system	It must be checked that the door is released from the self-holding					X		

	Subject	Control item	Control:					
			Visually	Annually	Bi-annually	Quarterly	Monthly	Daily
		function when the test button on the ABDL system is activated.						
16	Battery back-up	The battery must be replaced every 2 years. The battery is checked by turning off the power supply to the port.			X			
17	Accidental stress	If the door is subjected to collision that may have damaged the safety devices ensuing a risk of personal injury, an inspection must be carried out.	X					
18	Spare parts	When ordering spare parts the door number should be stated. The door number is located on the door sign, attached to the door.						
19	Cleaning	Wash with mild soapy water. Wash with a soft brush and rinse with clean water. Wiping required. Under no circumstances clean with agents containing solvents (gasoline, thinner, alcohol or similar), abrasive or polishing agents, or wax, as these will reduce the product's service life. When using chlorine-containing cleaning agents, thorough washing must be carried out. Prolonged presence of chlorides on the surface of the door will reduce the surface's overall service life. For thorough cleaning, use a cleaning agent designed for stainless steel and aluminium.						
20	Lubrication	Once cleaned, stainless surfaces are covered by acid-free oil, approved for the industry where the door is fitted.						
21	Before putting the door into operation	Once mounted, remove the foil from the door and frames and lubricate with acid-free oil until the steel is saturated. This is done to avoid rust film and other substances getting stuck on the surface. Repeat this treatment after each cleaning, which could wash off the oil.						

\*Not available for all door types.

## Statutory inspection

Annual statutory inspection includes the following:

- Automatic doors
  - Checking that the door is in a safe condition in terms of safety and health
  - The inspection must be carried out by an expert
- Fire doors
  - Hinges, suspension system and locking function are cleaned and lubricated.
  - The self-closing mechanism is checked and possibly adjusted.
- ABDL plant
  - Quarterly function check that the door closes correctly when the ABDL system's test button is activated.
  - 2-year inspection of authorized electrical installation company.

For a warranty on the doors, an inspection by Door System A/S is required (when creating a service agreement).





**Please direct any questions about the operations and maintenance to Door System's service department at +45 86 92 11 71.**

## Repairing faults

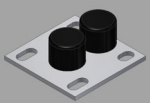
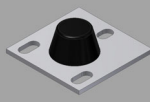
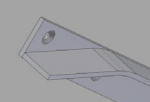
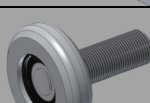
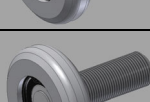
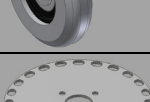
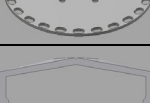
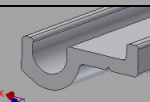
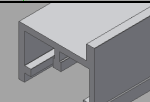
PROBLEM	POSSIBLE CAUSE	ERROR CORRECTION
The door will not open/close	Lack of power	Check to see if the power for the control is on. If not, switch on.
	The emergency stop may have been activated	Release the emergency stop by turning the red button to the right.
	The safety functions may be blocked	Check if the door frame photocells are correctly adjusted and if they are dirty.
	The automatic port may be set incorrectly	Check the parameter settings according to the description of parameters in the door control document.

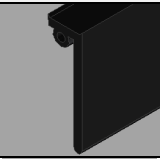
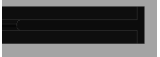
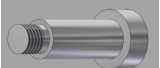
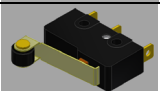
## Spare part list

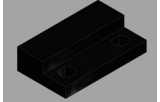
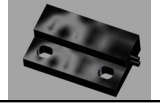
No.	Description	Item no.	
1	Bottom guide rear, complete	200-100	
2	Bottom guide front, complete	200-101	
3	Bottom guide rail, Left/Right, 60/100/150 mm	200-250	
4	Roller with stud bolt L69, Ø64 POM	20-1010	
5	Roller with stud bolt L69, Ø64, stainless steel	20-2520	
6	Perforated disc for sensor, oblong hollow/hole (DS280-700, belt-driven)	27-0009	
7	Aluminium list (lid), type E (for seal 42-0040)	41-0013	
8	Aluminium list, type B (for seal 42-0016)	41-0015	
9	Aluminium profile for tooth bar	41-0025	

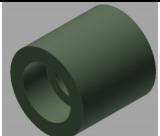
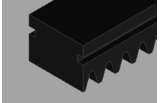
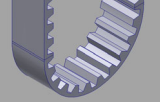
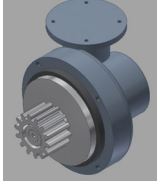
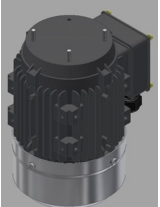
No.	Description	Item no.	
10	Sealing strip type B1, black (bottom seal)	42-0016	
11	Sealing strip type A, black (side seal)	42-0040	
12	Tight fitting bolt M12-16-40 FZB	70-5004	
13	Micro-switch with roller arm SS-5GL2	84-0200	
14	Magnetic sensor HP 140505 (rack pull)	84-0205	
15	Magnet 14x23	84-0207	
16	Magnet sensor 14 x 23	84-0208	
17	Proximity sensor 2 M (toothed belt pull)	84-0212	
18	Heating unit 24V/3W (for cylinder lock )	84-0230	
19	Backstop roll for tooth bar	85-1015	
20	Toothed bar, POM	85-1050	
21	Toothed belt, M8-20-ST	85-1135	
22	Gear type DS 1:20 BJ (toothed bar)	85-1200	
23	Motor 0.55kW. 3000 rpm B14 (toothed bar)	85-1210	

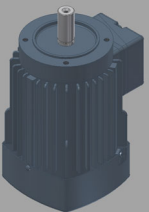
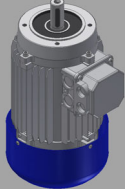

No.	Description	Item no.	
24	Motor, Vem 1.5 kW.1000 rpm DS-RT (belt drive)	85-1219	
	Motor, Vem 1.1 kW.1000 rpm DS-RT (belt drive)	85-1220	
25	Motor, Vem with brake 1.5 kW.1000 rpm DS-RT (belt drive)	85-1222	
	Motor MT with brake 1.1 kW.1000 rpm DS-RT (belt drive)	85-1221	